

PRODUCT SPEC SHEET/KEY SPECIFICATIONS

FOUNDATION VENTS Model # FV2021-PG

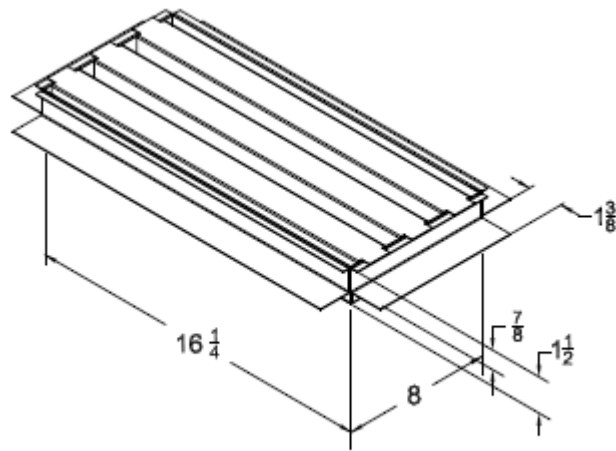
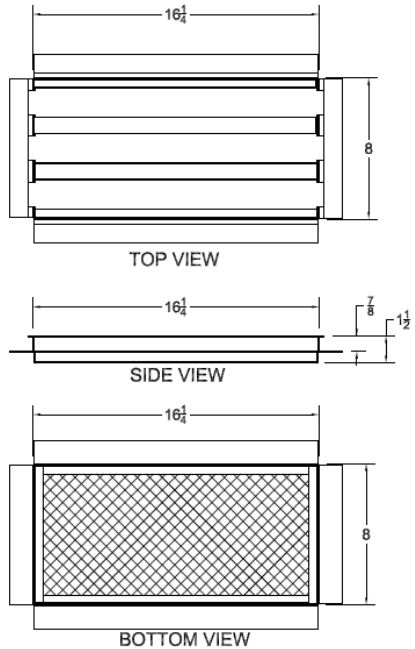

Foundation Vents	Model	Size L x W	NFVA Provided	Flanges available	Flange Definition	Weight
	FV2021-PG	16" x 8"	38	For Stucco prior to application	Flange with J Channel	5lbs
CUSTOM SIZES AVAILABLE						

BENEFITS:

- Safety vents that are used in areas prone to wildfires, wind driven rain, or wind driven snow.
- Overlapping Baffle Protection (Patent Pending)
 - Air Flow through normally
 - Resists the intrusion of Flame and Embers, Wind Driven Rain and Wind Driven Snow
- Compliant with new California Ch7a Building Code
- 20 Year Warranty
- Easy Install

STANDARD MATERIALS

$\frac{3}{8}$ " Mesh Standard unless otherwise requested

Astm A653/A653M- G90 hot dipped galvanized steel, 26GA

ASTM D9092- mill phosphatized coating for painting, if bonderized

ASTM b370- Sheet Copper, 16oz and 20oz, if copper

Installation: Install like any other similar Ventilator Product on the market.