

PRODUCT SPEC SHEET/KEY SPECIFICATIONS

UNDER EAVE/SOFFIT VENTS Model # UE2041-RS

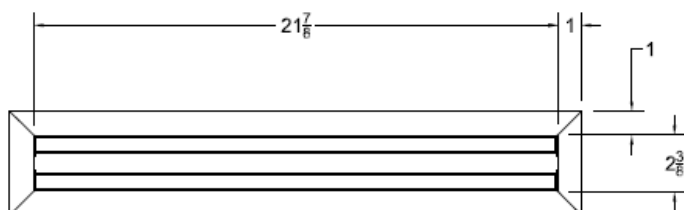

TOP VIEW

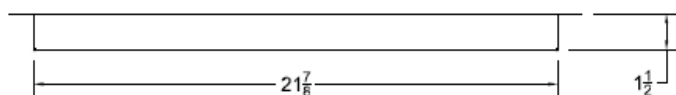

SIDE VIEW

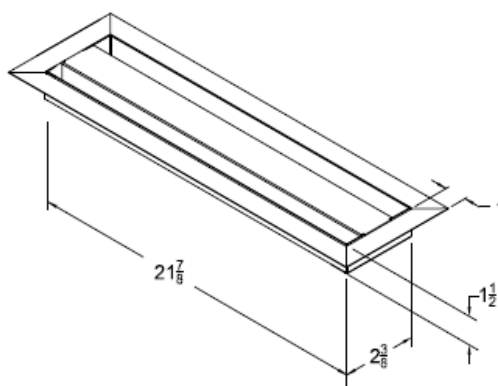
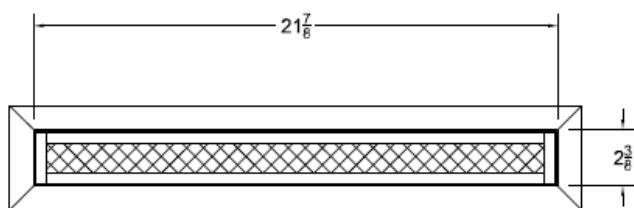

Under Eave/Soffit Vents	Model	Size L x W	NFVA Provided	Flanges available	Flange Definition	Weight
	UE2041-RS	22" x 3"	22	Retrofit Soffit	1" w Front Flange	5lbs
Continuous Vents and other CUSTOM SIZES AVAILABLE						

BENEFITS:

- Safety vents that are used in areas prone to wildfires, wind driven rain, or wind driven snow.
- Overlapping Baffle Protection (Patent Pending)
 - Air Flow through normally
 - Resists the intrusion of Flame and Embers, Wind Driven Rain and Wind Driven Snow
- Compliant with new California Ch7a Building Code
- 20 Year Warranty
- Easy Install

STANDARD MATERIALS

1/4" mesh standard unless otherwise requested

Astm A653/A653M- G90 hot dipped galvanized steel, 26GA

ASTM D9092- mill phosphatized coating for painting.- If bonderized

ASTM b370- Sheet Copper, 16oz and 20oz- if copper

Installation: Install like any other similar Ventilator Product on the market.