

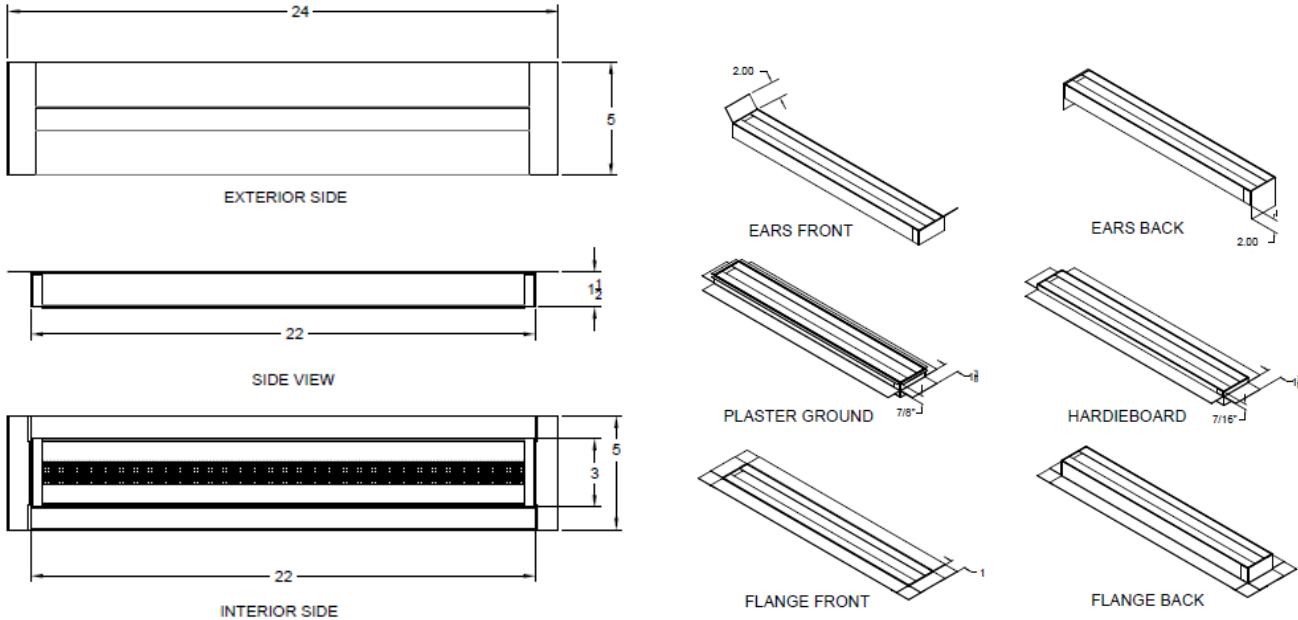

PRODUCT SPEC SHEET/KEY SPECIFICATIONS

“EXTREME EAVE” UNDER EAVE/SOFFIT VENTS Model # UE3041 22” x 3”



| Under Eave/Soffit Vents | Model | Size L x W | NFVA Provided | Flanges available | Flange Definition | Weight |
|-------------------------|--------|------------|---------------|-------------------|-------------------|--------|
| | UE3041 | 22" x 3" | 20 | See above | See above | 3lbs |
| CUSTOM SIZES AVAILABLE | | | | | | |

BENEFITS:

- Safety vents that are used in areas prone to wildfires, wind driven rain, or wind driven snow.
- Overlapping Baffle Protection (Patented)
 - Air Flow through normally
 - Resists the intrusion of Flame and Embers, Extreme Radiant Heat, Wind Driven Rain and Wind Driven Snow
- Compliant with new California Wildfire Building Code 2016
- California Building Materials Listing (BML) # 8160-2232:0500
- 20 Year Warranty

STANDARD MATERIALS

1/8" mesh standard unless otherwise requested

Astm A653/A653M- G90 hot dipped galvanized steel, 22GA

2x intumescent adhesive strips installed on internal baffles to provide extreme radiant heat protection

ASTM D9092- mill phosphatized coating for painting.- If bonderized

ASTM b370- Sheet Copper, 16oz and 20oz- if copper

Installation: Install like any other similar Ventilator Product on the market.